

National Programme
of
Mid Day Meal in Schools

[MDMS]



Annual Work Plan And Budget

2012-13

KERALA

MID DAY MEAL PROGRAMME

1. Introduction

- 1.1 The Mid Day Meal Scheme was first introduced in the state of Kerala in 1984 in the LP Schools functioning in 222 Villages, having Fishermen as majority. During 1985 the scheme was extended to all LP schools (Std. I to IV). The scheme was extended to Upper Primary Schools (std. V to VII) during 87-88. The scheme was further extended to the students of Std.VIII during 2007-08. The scheme consists of supplying cooked food to the children using rice, pulses, and coconut oil/palmolen.

Government of India launched the above scheme as a Centrally Sponsored one on 15th of August 1995. The centrally sponsored scheme originally covered the children of primary stage studying in Std. I to V in Govt./ Local bodies/ Govt. Aided Schools. The scheme was further extended to the children studying in Education Guarantee Scheme (EGS) and Alternative Innovative education centers also, in October 2002. During this academic year the scheme was extended to Upper Primary section also.

By implementing the scheme it is hoped that at least 90% class attendance can be ensured every day and drop out of pupils in the midst of an academic year can be avoided. The outcome of the scheme is not only to give food to school pupils by Government but also to make the children eat a common dish at a common place in their respective school premises and thereby establish cordial relationship, mutual understanding, healthy friendship and emotional unity among children.

1.2 GOI+ State

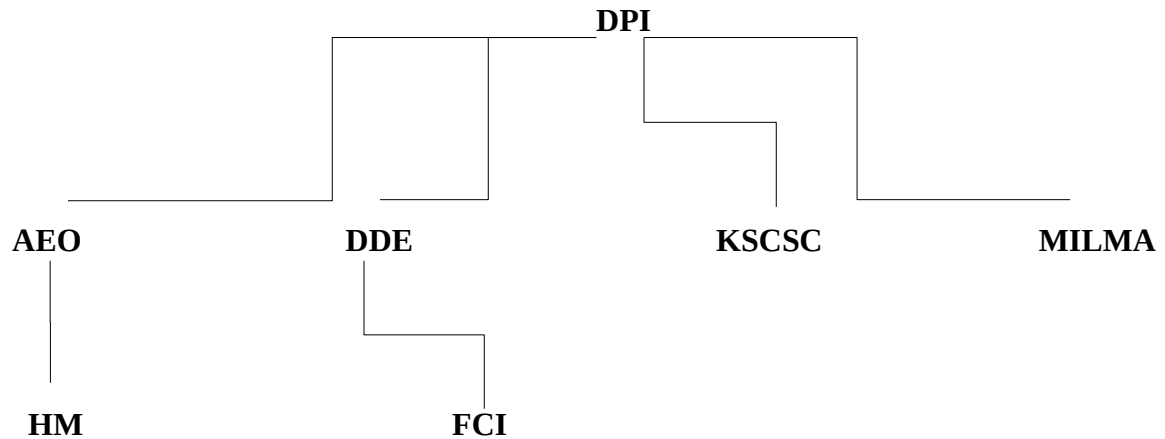

1.3 The AWPB is evolved after detailed discussion based on the data from the field and the resources that can be made available from the state for the implementation for the scheme. The Director of Public Instruction led from the front for this entire process of AWPB preparation. The other officials involved in the implementation of the MDM Scheme also participated in the process of the AWPB preparation.

2.1 During 2011-12 the MDM scheme is being implemented without any interruption. The Director of Public Instruction is the Nodal Officer of the MDM Scheme in Kerala. State level Management, Monitoring & Evaluation of the scheme is done by the State level Steering cum Monitoring Committee with Secretary to Government (General Education) as the chairman and the Director of Public Instruction as the Member Secretary & Convener. District level Steering cum Monitoring committee is headed by the District collector and Deputy Director Education as secretary. At block level, Block Panchayat President is the Chairman and the Assistant Educational Officer is the Secretary. For effective Implementation of the Programme in schools, a school level committee is constituted with PTA President as Chairman and the Headmaster of the school as the Member Secretary.

2.2 There is no NCLP School functioning in the state.

2.3 The Kerala State Civil Supplies corporation is the nodal agency for lifting the food grains from FCI and supplying to the implementing agencies through Maveli Stores. The HM in charge of procuring food materials(rice, pulses etc) from the outlets of Civil Supplies Corporation. Deputy Director of Education is designated as the Nodal Officer for supervising the lifting of rice from FCI.

Food Grain Flow Chart

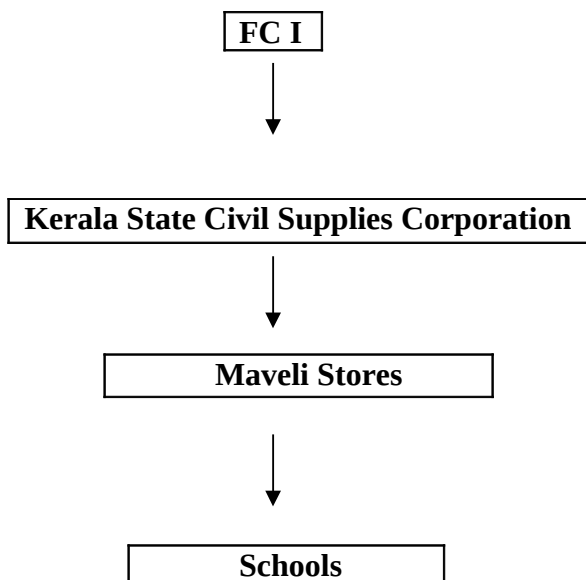

2.4 Deputy Director Education is designated as the Nodal Officer for making payment to FCI without any delay. Cost of rice will be placed at the disposal of the Deputy Director Education in two installments for making payment promptly.

System for Payment of Cost to FCI

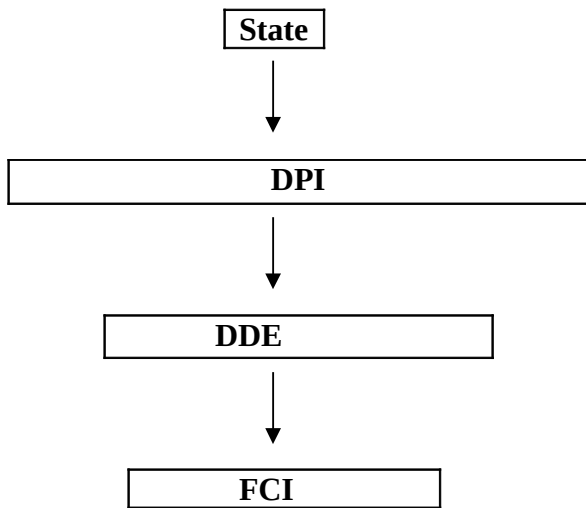

There is no pending bills of FCI of the previous year.

2.5 Fund Flow

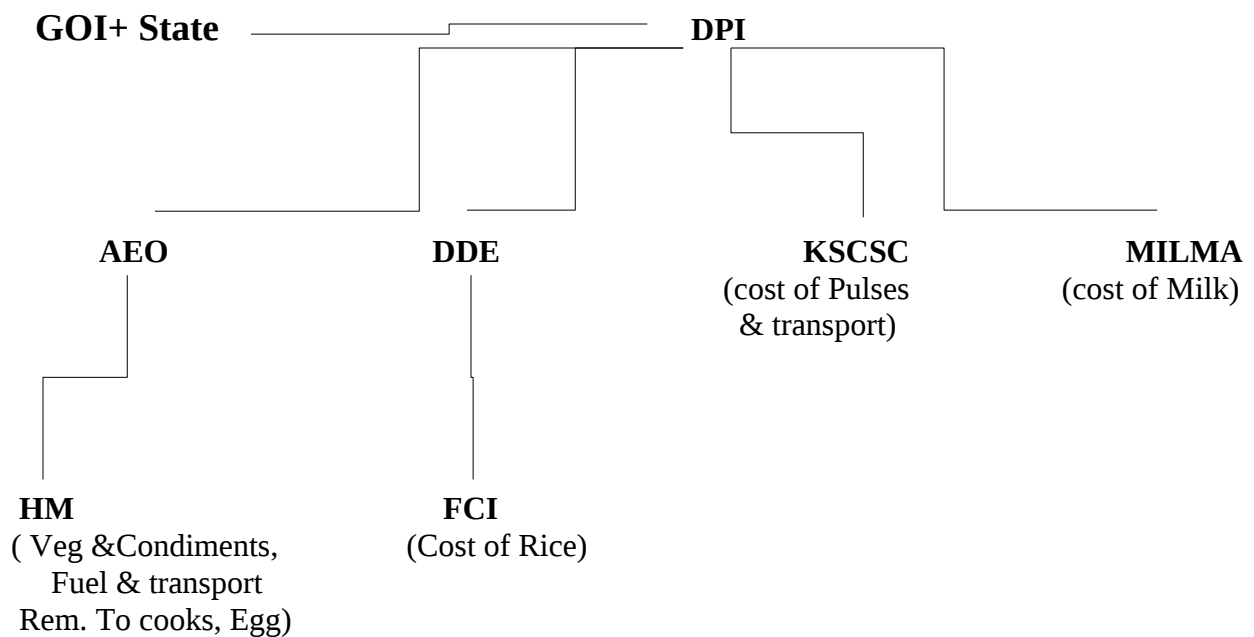

First instalment of cooking cost will be released to AEOs by 1st week of June. Second instalment will be released by 1st week of October and third instalment by 1st week of January. The AEOs release the funds to schools immediately on receipt of the funds from DPI.

- 2.6** Table attached.
- 2.7** In Kerala, MDM Scheme is being implemented by the school Noon Feeding Committee. Remuneration to cooks is disbursed by the HMs.
- 2.8** Headmaster is in charge of procuring food materials (rice, pulses etc) from the outlets of Civil Supplies Corporation. Condiments, oil, fuel etc are procured locally by the school committee.
- 2.9** The meal is prepared in the school premises (in Kitchen shed). Members of mother PTA are actively participating in cooking and serving of food. The presence of mother PTA ensures the quality of food. Teachers taste the food and supervise the serving of food.
- 2.10** In Kerala, the mid day meal scheme was started during 1984. Permanent or semi permanent kitchen shed were put up in each and every school since 1985. In Govt. aided schools kitchen shed were constructed by the school managers. In Govt. schools, kitchen sheds were constructed by Govt. or by the PTA. As the scheme is extended to UP section also, in most of the schools, the storage facility and kitchen shed is not adequate for the present need.
- .
- 2.11** The funds released by GOI are allotted to school authorities for procuring the Kitchen devices so as to select the item for their need. In most of the schools, the kitchen devices are provided by the PTAs

- 2.12** Orientation was given to the staff involved in implementation and monitoring the Mid Day Meal Scheme.
- 2.13** School authorities submit utilization of food grains and stock position to the Assistant Educational Officer every month. 163 AEOs(Block level) in the state are connected online and data from the Sub District can be accessed from the Directorate.
- 2.14** For the implementation of the programme in schools, a committee is constituted with PTA President as President and Headmaster as the Member Secretary. Other members of the committee are one member from Local Self Government, two teachers (one should be a woman), one member from mother PTA, two representatives from parents of feeding students belonging to SC/ST. Involvement of PTA and MPTA ensures the transparency of the programme. The Head of the school keeps attendance of the students participating in the MDM scheme every day. The HM also keeps stock register (K2 Register). Stock register is updated every day.
- 2.15** Till 2010, funds towards cooking cost were distributed through PRI concerned. This routing of funds through PRIs causes much delay. To avoid the delay, we have introduced e-transfer of the funds directly to the AEOs and the AEO e-transfer the funds to HM's account.
- 2.16** Evaluation study has not been conducted during the current academic year.
- 2.18** Involvement of mother PTA and ward members ensures the quality of food. There is no incident of unhygienic food served or students fallen ill after having food.
- 2.19** For the implementation of the scheme, School Noon Feeding committee consisting of PTA President, members of Mother PTA, Ward Member, Head of the institution, teacher's representatives is constituted. There is no involvement of NGOs in implementing the Scheme. PRI is involved in monitoring the implementation.

- 2.20** School Health programme is being conducted by the Health and Social welfare department with help of PRIs.
- 2.21** The Noon Feeding Supervisors, the Dist Educational Officers and Assistant Educational Officers are engaged for the monitoring the scheme. The SMCs at various levels are functioning properly.
- 2.22** There is a Noon Feeding Supervisor in the district. The supervisor visits the schools and examines the food served and verifies the stock and other records. The Assistant Educational Officer, District Educational Officer and Deputy Director Education visit the schools and monitor the mid day meal scheme. Vehicle is provided to all Deputy Directors Education for their school visit. There is a committee at school level for the implementation and monitoring the scheme
- 2.23** The Noon Feeding Supervisor is the officer engaged for inspection of the MDM centers in the District. He could cover only 60 to 70 percent institutions.
- 2.24** There is no adverse comment received from the monitoring institution so far.
- 2.25** A grievance redressal forum is constituted at state level with PTA members, representatives of teachers' organization, DPI, Local body authorities etc.
- 2.26** Media campaign has not been conducted during the current academic year.
- 2.27** The Mid Day Meal Programme is being implemented in the state in a good manner. However the present system of implementation of the scheme needs some changes to improve the quality of food , cooking cost and transportation cost. It is suggested to provide Special fund to convert all the kitchen to Gas based instead of using firewood.